



# T5<sup>TM</sup>

Point-of-Care  
Technology Cart



# T5 Point-of-Care Technology Cart

The first truly ergonomic workstation-on-wheels solution solution, Humanscale's T line of point-of-care technology carts offers fresh solutions to today's healthcare IT challenges.

Humanscale's award-winning T5 teams unmatched mobility and comfort with a high-performance power system for both laptops and PCs. Designed to meet the ergonomic requirements of 99% of users in both sitting and standing postures, the T5 provides independent adjustability of the keyboard, monitor, work surface and overall cart height for maximum user comfort. Plus its minimal footprint ensures effortless maneuverability in tight corridors, around hospital beds, and other compact spaces.

The T5's optional energy-conscious and quick-charging internal power system stays cool without a fan—which helps limit the spread of contagions. Power reserves may be easily monitored from both a graphic computer interface and a unique remote power management system that relays information to a central location within a healthcare facility.

Designed with the environment in mind, the T5 contains more than 50% recycled materials and is itself 95% recyclable.

## Research-Driven Design

Extensive research and interviews with regular Workstation on Wheels users led to the development of key features of the T5, including:

- Comfort for the widest range of users
- Ease of mobility
- Maximum maneuverability in confined spaces
- Long-lasting power

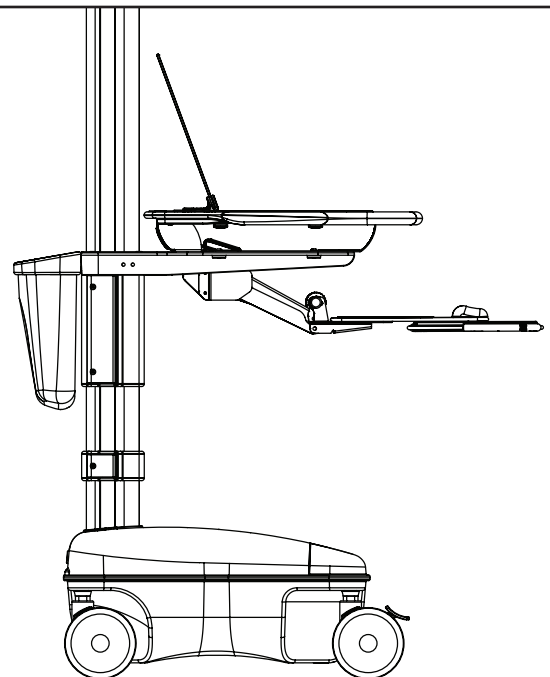

# Specifications & Features

## Ergonomic Adjustability

- Accommodates the ergonomic needs of 99% of all users, sitting and standing
- Patented one-touch keyboard/mouse support technology
  - 25" to 43" adjustment range
  - Optional extra 5" of keyboard height adjustment
  - 0° to -15° keyboard tilt for low-risk keying posture
  - Adjustable mousing surface for both left- and right-handed users
  - Technogel® palm support with wipeable, anti-microbial cover
- PC model provides monitor adjustability
  - 40" to 58" adjustment range
  - Optional extra 6" of monitor height adjustment
  - 30-degree tilt range
  - 360-degree monitor rotation
  - Work surface adjustment range: 28" to 46"
- Foot pedal provides simple overall changes in cart height
- Easiest Workstation on Wheels to move and maneuver
  - Push-pull handle accessible from three sides
  - Steel ball bearing casters roll smoothly on both hard and carpeted surfaces and provide less than two pounds of push/pull resistance
  - Casters' large diameter allows for easy movement over flooring transitions and on/off elevators

## Hardware Support

- Laptop computer version accommodates notebooks up to 17"
- PC version supports most CPUs and thin client server devices
- Small form factor compatible
- Supports dual-monitor applications

## Optional Power System

- Four Power Systems to choose from:
  - 40 amp/hour SLA power system
  - 60 amp/hour SLA power system
  - 230 volt output system for international applications
  - 40 amp/hour Li-ion power system (a green solution that offers shorter charge time, longer battery life and lighter weight)



# Specifications & Features



## Security & Safety

- Unique security system protects hardware against theft
- Front-locking casters
- Customizable spill protection for laptop computers
- Fan-free power system helps limit spread of contagions

## Warranty

- Five-year warranty on all parts with the following exceptions:
  - Power supply: 3 years
  - Battery: 90 days
  - Enrollment in optional battery replacement program available at time of purchase
  - Best service and warranty program in the industry

## Sustainability

- Contains 50% recycled materials
- 95% recyclable
- Energy-efficient power system

## Additional Details

- Inset work surface keeps objects from falling
- Utility container positioned for easiest accessibility
- Cable management system
- Optional add-ons include peripheral shelves, printer shelves, barcode scanner clip, vital signs monitor, equipment mounts, glove and wipes dispensers, sharps holders, and cup and bottle holders
- Antimicrobial and easy-clean finishes
- Improved power access and wire management at head assembly
- Custom writing surfaces available



Creating a more comfortable place to work

[www.humanscale.com](http://www.humanscale.com)  
800.400.0625 ext. 6